

Introduction

This product manual is intended for users and servicers of the CSWE1 Automatic Ice Machine.

Table of Contents

Specifications:	2
Installation:	3
Plumbing:	4
Initial Start Up	5
Changing the bin door and lower panels.	6
What to expect:	7
Maintenance:	8
Cleaning the interior components.	9
Condenser	10
Service Diagnosis	11
Service Diagnosis	12
Service Diagnosis	13
Operational Characteristics	14

Keep this manual for future reference.

A parts list is located in the center of this manual, printed on yellow paper.

This manual is printed on recycled paper.

CSWE1

Specifications:

This ice machine requires 115 volts AC. It is designed only for indoor installations, in a controlled environment.

Limitations:	Minimum	Maximum
Air Temperature	55°F.	100°F.
Water Temp.	40°F.	100°F.
Voltage	104	126
Water Press.	20 psi	80 psi

It will fit in a space 18" wide and 34.5" high and 24" deep. A potable water supply and drain is required.

Scotsman Ice Systems are designed and manufactured with the highest regard for safety and performance. They meet or exceed the standards of UL, NSF and CSA.

Scotsman assumes no liability or responsibility of any kind for products manufactured by Scotsman that have been altered in any way, including the use of parts not specifically approved by Scotsman. Scotsman reserves the right to make design changes and/or improvements at any time. Specifications and designs are subject to change without notice.

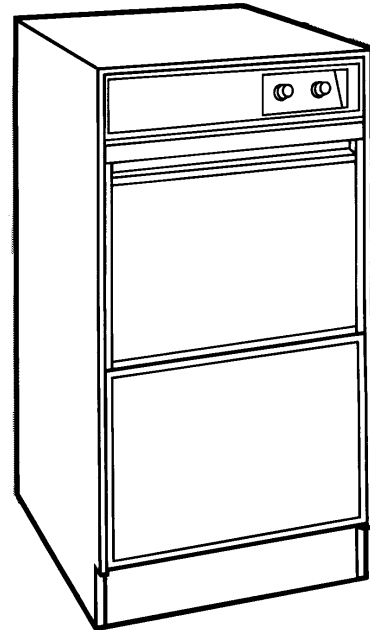

Refrigerant charge is 6.75 oz. of R-134a.

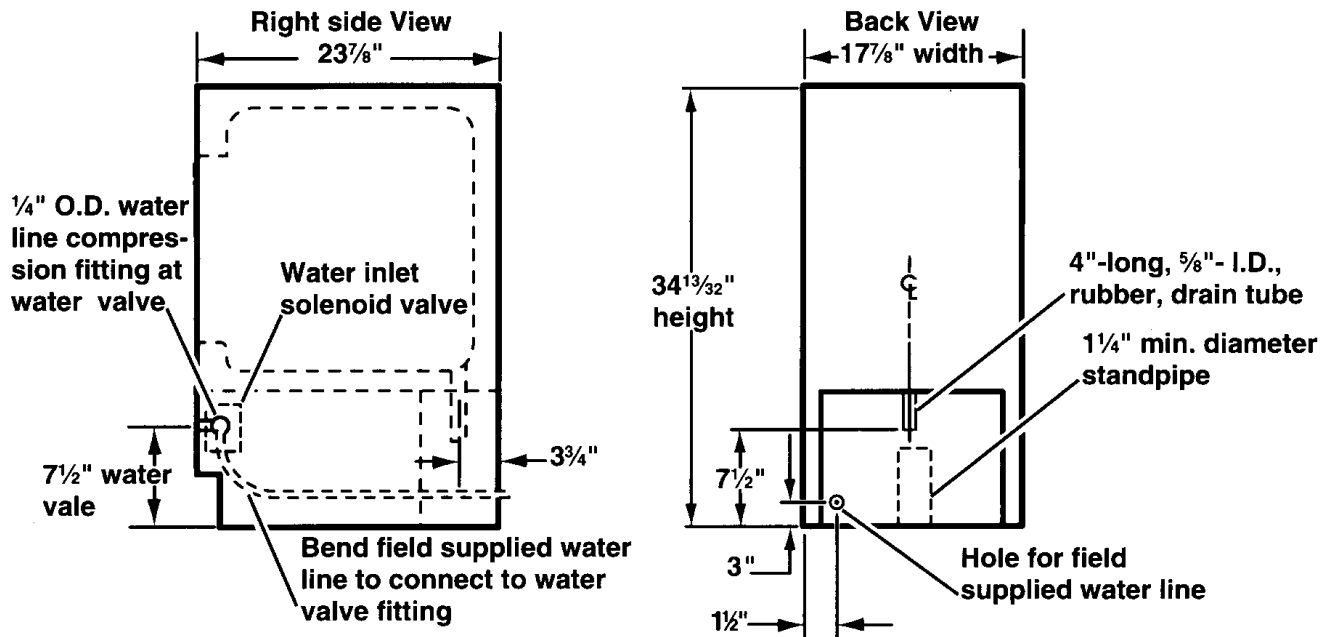

Installation:

Proper installation is a necessity, because an improper installation will cause operational problems that are NOT covered by any warranty. It is the customer's responsibility to contact a qualified installer.

Proper electrical supply, water supply and floor drain must be available. An electrical ground is required.

Do NOT close in the front of the ice maker. The ice machine requires space at the front base to discharge warm air.

If required by sanitation codes, seal the cabinet to the floor with an approved sealant. Legs are not available for this machine.

Location:

The ice machine must be installed indoors, in a controlled environment. There must be room to open the ice machine door and room to move the ice machine out for service, if needed.

The unit may be built in at the top, sides and back.

Electrical:

Follow all local, state and national codes. If needed, obtain the services of a licensed electrician.

1. A separate 115 volt, 15 amp circuit is recommended. A ground is required.
2. Do not use an extension cord. Have a grounded outlet installed close enough to the planned installed position of the ice machine so that the ice machine's plug can be plugged in directly.

Parts and features

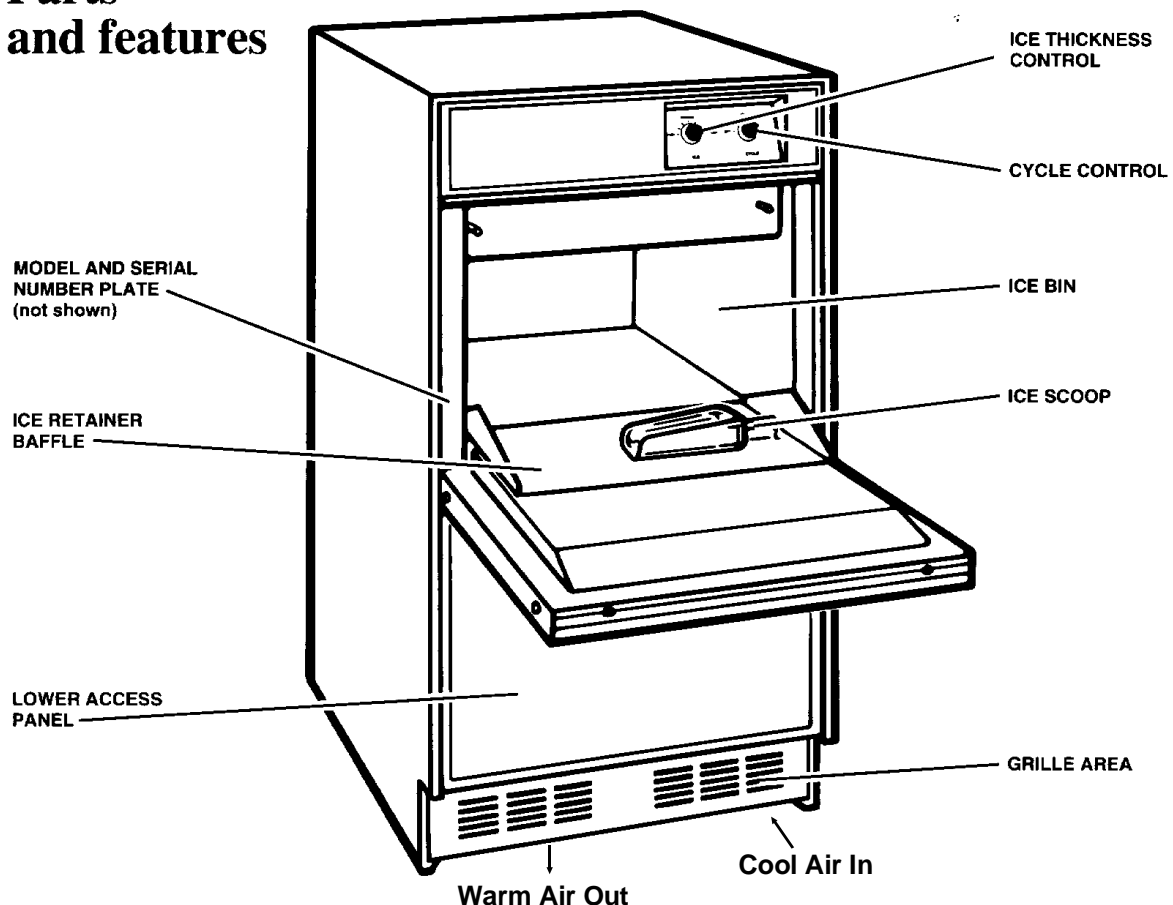

CSWE1

Plumbing:

Connect a 1/4" OD copper tube to a threaded compression fitting on the inlet water valve. There is an access hole in the back of the cabinet for routing the tube.

1. Remove the two screws in the lower grille area and one screw from the center panel support. Pull forward and down to remove the lower access panel.

2. While the panel is off, rotate the fan to check that it moves freely.

3. Open the ice bin door, and slightly loosen, but Do Not Remove the thumb screws holding the cutter grid and water pan in place.

4. Have a shut off valve installed on the potable cold water supply tubing near the ice machine.

5. Connect to the shut off valve sufficient length of 1/4" OD copper tubing to connect to the ice machine.

6. Route the 1/4" copper tubing through the hole in the back of the cabinet. If the machine is to be built in, route the tubing so that it will extend past the front of the cabinet when the cabinet is pushed into its installed position.

7. Flush the water line into a bucket to discharge any dirt that may be in the line.

8. Locate the drain tube at the back of the cabinet. Determine the required location of the drain tube when the cabinet is in its correct position, and install a 1 1/4" minimum diameter standpipe directly below where the drain tube outlet will be. Add insulation to the outside of the drain tube if desired. Follow all local codes regarding requirements for air gaps.

9. Plug the ice machine into a grounded outlet.

10. Slide the ice machine back and observe that the water inlet tube moves forward thru the ice machine.

11. An adapter fitting is furnished in the ice machine's parts bag. Place it on the inlet water valve and connect the 1/4" OD tube to it. Be sure it is water tight.

12. Check the level of the ice machine front to back and left to right. Shim as needed.

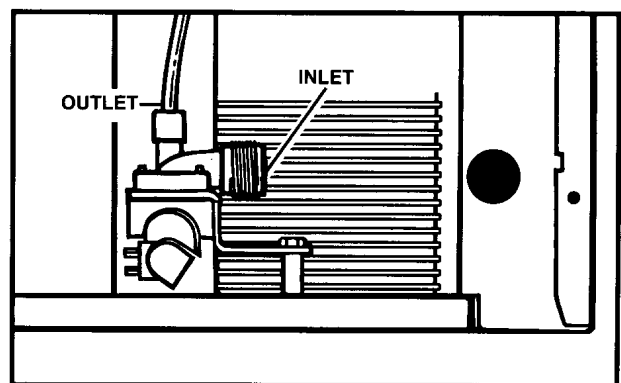
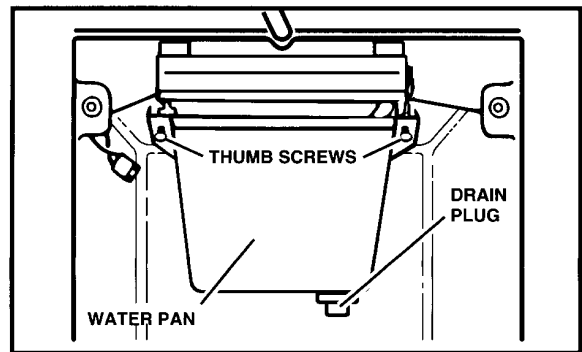
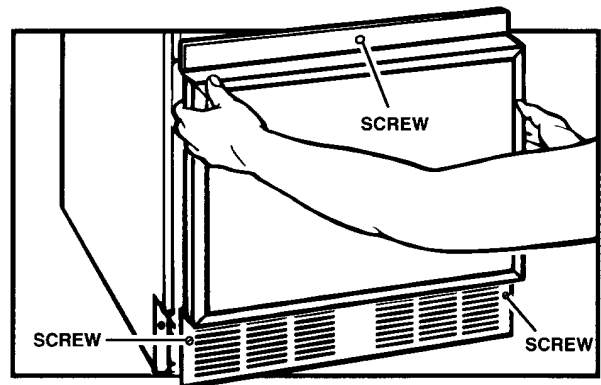

Initial Start Up

Note: If the ice machine is installed above 2,000 ft. the bin and evaporator thermostats will need to be adjusted. Remove the thermostats and adjust them as shown on the labels of the thermostats. Return the thermostats to their original positions after adjustment.

1. Open the hand water shut off valve and check for leaks at the inlet water valve. Tighten tubing as needed.
2. Replace the lower access panel.
3. Switch on the electrical power.
4. Switch the ice machine on by rotating the control knob to the CLEAN position. The water pump should be operating.
5. Rotate the control knob to the ON position. The fan in the cabinet should be blowing air in and out of the front grill.

The ice machine will begin to make ice, but do not expect much production for the first 3 hours.

Do not adjust ice thickness until the machine has run for 24 hours.

6. After 24 hours of run time, check the ice thickness. If needed, adjust thickness by rotating the ice thickness knob. The best thickness of ice is $\frac{1}{2}$ ".

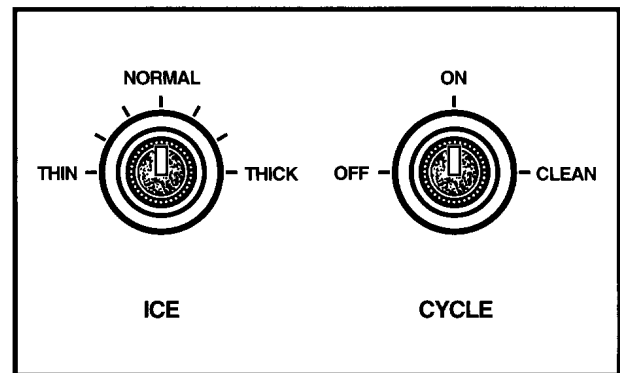
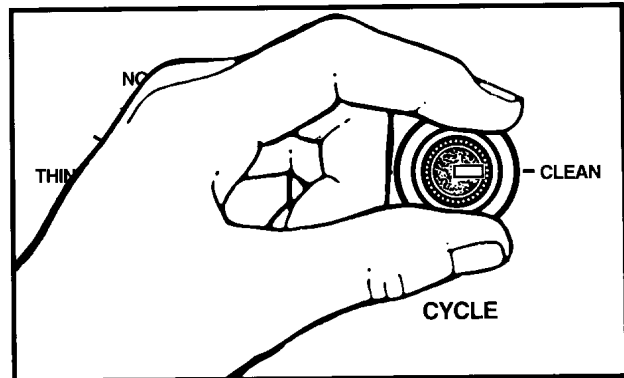

CSWE1

Changing the bin door and lower panels.

The bin door and lower panels can be customized to match wood cabinets. The size of the door panel is: 11 1/4" high x 17" wide. The size of the lower panel is: 11 15/16" high x 17" wide.

1. Cut panels, making sure that the wood grain matches the direction of the cabinet wood grain. It is a good idea to cover the edges of a wood panel with moisture resistant sealant.

2. Open the bin door and remove the two screws holding the handle to the top of the door, remove the handle.

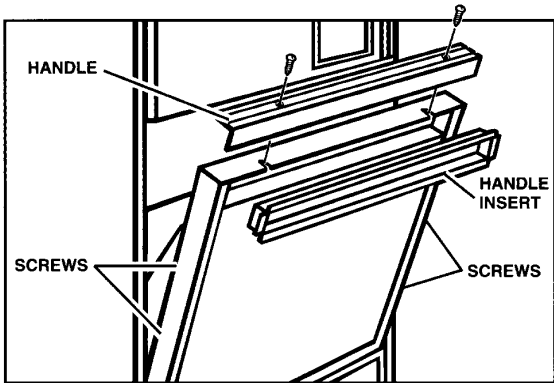

3. Slide the metal panel out of the door.
4. Break off the ribs on the door insulation.
5. Slide the wood panel into the bin door frame.
6. Reattach the handle with the two screws.

Lower Panel:

1. Remove the three screws that hold the lower panel assembly and the two screws at the top of the lower panel. Remove the top of the lower panel assembly.

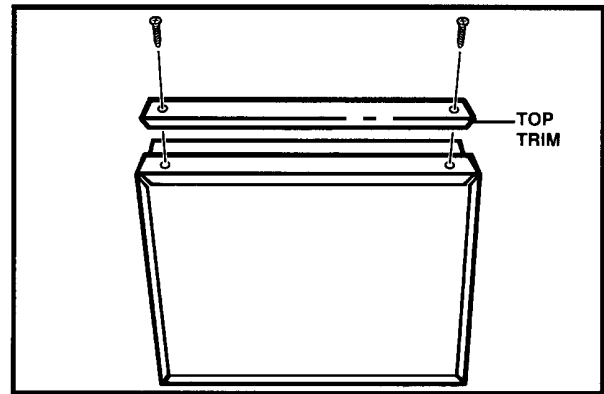
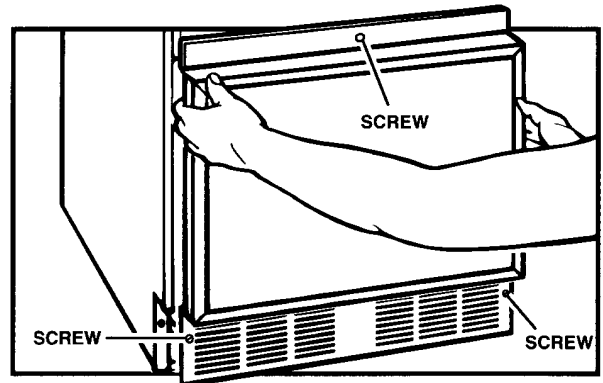

2. Slide the metal panel and the spacer panels out of the lower panel assembly.

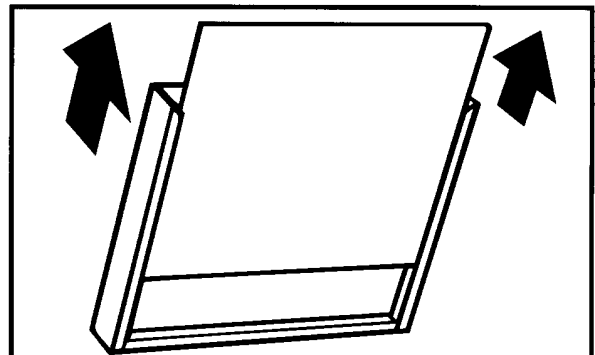

3. Slide the metal panel back into the lower panel assembly, slide the wood panel in front of the metal panel.

4. Reattach the top of the panel with the two screws and replace the three screws that hold the lower panel assembly.

What to expect:

When the machine is on, and making ice the compressor, fan motor and water pump will be on. Periodically, the water pump and fan will stop and ice will be "harvested".

The ice machine must have good ventilation in order to work properly. Do NOT block the air flow in front of the machine.

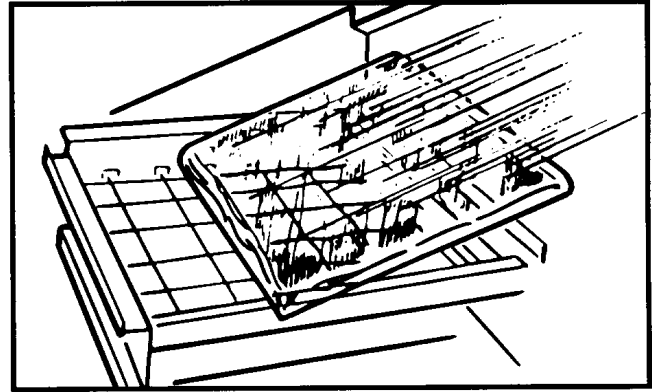
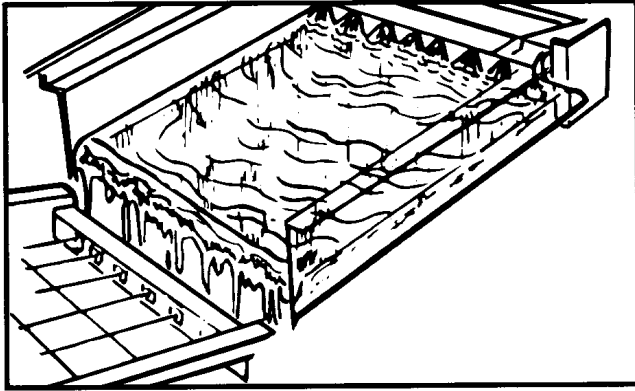

Water flows over an inclined freezing surface, and gradually freezes into a slab. The ice size thermostat measures the temperature of the freezing surface and the setting of that thermostat determines the thickness of the slab.

During the ice release cycle, the ice slab slides down onto a hot wire cutter grid and, after the grid melts thru the ice, the individual cubes fall into the ice storage bin portion of the machine.

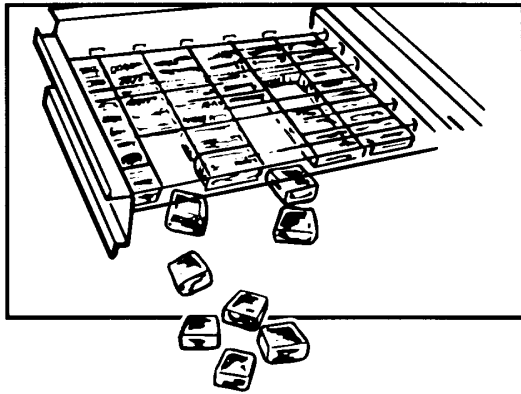

The ice machine will continue to produce ice until the bin is full. Then the ice machine will shut down until the level of ice in the bin falls below the bin thermostat well.

The ice storage bin is not refrigerated, so there will be some melting. This will vary with the temperature of the room where the ice machine is located.

CSWE1

Maintenance:

The water system, including the filter screen in the inlet water valve, needs to be cleaned periodically. Instructions are located on the inner door panel.

Water System Cleaning:

1. Place the cycle control knob in the Off position.
2. Remove the two thumb screws, and slide the ice cutter grid forward, out of the two slots near the water pan.

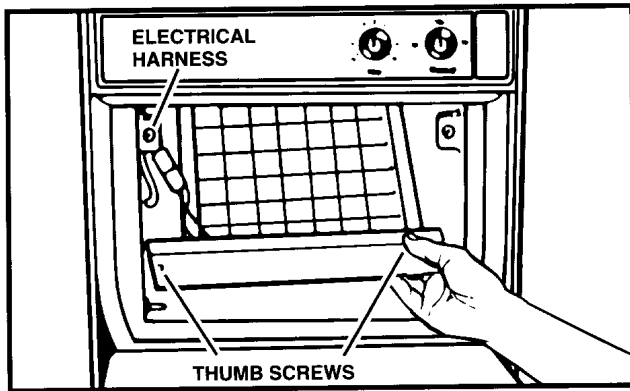

3. Unplug the electrical harness.
4. Remove all ice from the storage bin and the freezing place.
5. Drain the water pan by removing the drain plug. When finished, replace the drain plug.

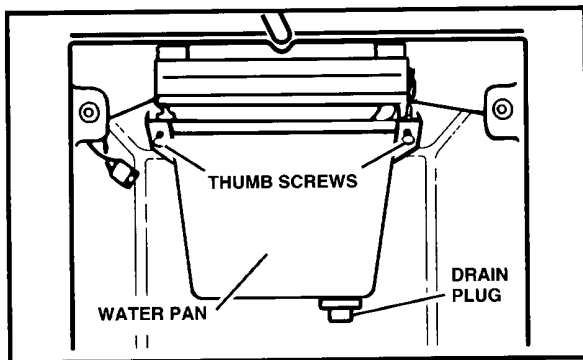

6. Pour 2 quarts of hot water into the water pan and turn the cycle control to "clean". This step warms up the system and allows the cleaning solution to be more effective. All the circulate 5 minutes. Turn switch to 'Off' and drain.

Prepare the cleaning solution by thoroughly mixing 2 ounces of Scotsman Ice Machine Cleaner into 2 quarts of hot (95°F - 115°F.) water. An alternative solution is 6 ounces of powdered citric acid and 2 quarts of hot water.

▲WARNING	Scotsman ice machine cleaner contains acids. Acids may cause burns.
	If swallowed do not induce vomiting. Give large amounts of water or milk. Call Physician immediately. In case of external contact, flush with water. Keep out of the reach of children.

7. Pour cleaning solution into water pan and turn the switch to "Clean". If solution foams while pouring, stop until foaming subsides, then add balance of solution. Allow solution to circulate until scale has dissolved. The circulating solution may not contact scale on the side flanges of the freezing plate. To remove this scale, wear rubber gloves and use a stainless steel sponge or pad dipped in cleaning solution to scrub the side flanges until the scale is removed. Generally scale will be dissolved in 15 to 30 minutes. Severe scale formation may require repeating the cleaning process with a fresh quantity of solution if the scale has not dissolved after 30 minutes.
8. Turn switch to "Off" and drain.

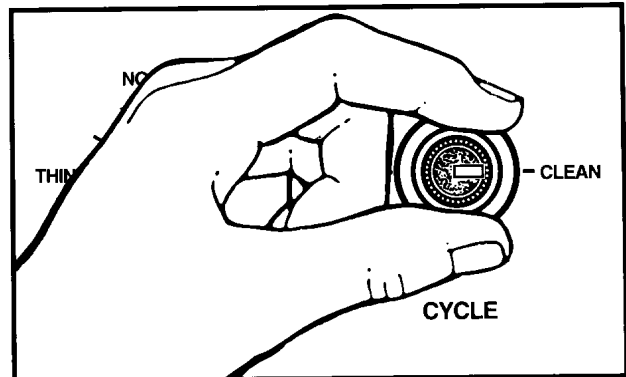

9. Follow cleaning with two fresh water rinses, circulating each rinse for 5 minutes, and drain.
10. This completes the "in place" cleaning and sanitizing of the water system and freezing plate. Other interior components must also be cleaned and sanitized.

Cleaning the interior components.

1. Turn the cycle control knob to "Off" and disconnect the electrical power supply to the ice machine. Open the storage bin door and remove any ice that is in the bin.

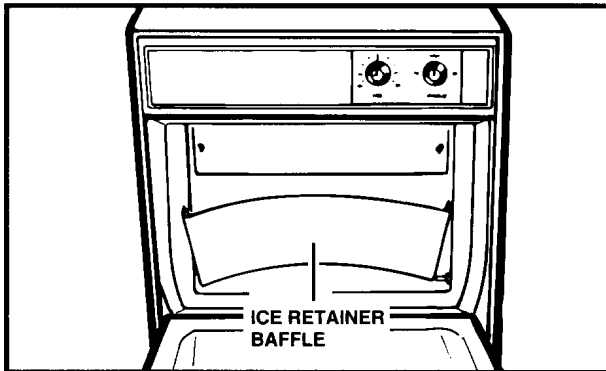

2. Remove the ice retainer baffle by flexing it and sliding it off the studs.

3. Remove the ice cutter grid by unscrewing the two thumb screws, sliding the grid forward, and unplugging the electrical wire harness.

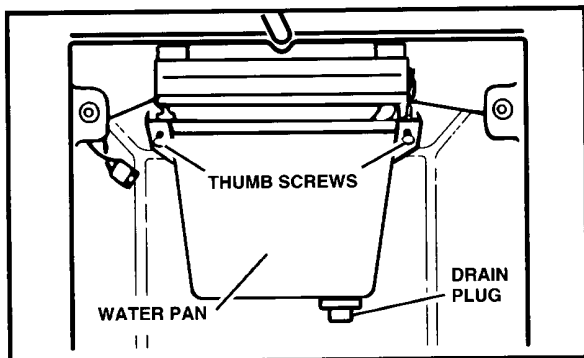

4. Remove the water pan by unscrewing the two thumb screws.

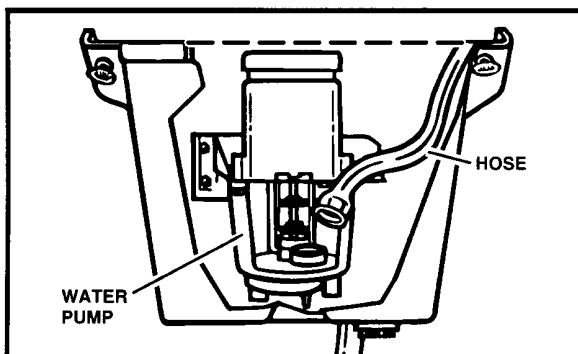

5. Remove the hose from the water pump.

6. Remove the water distributor from the freezing plate. It is held in place by rubber end caps. Remove the inlet hose and clean all water distributor holes and the small orifice in the inlet side of the distributor. When replacing the distributor, make sure the end caps are located in the evaporator flange detents and that the water distributor holes face down.

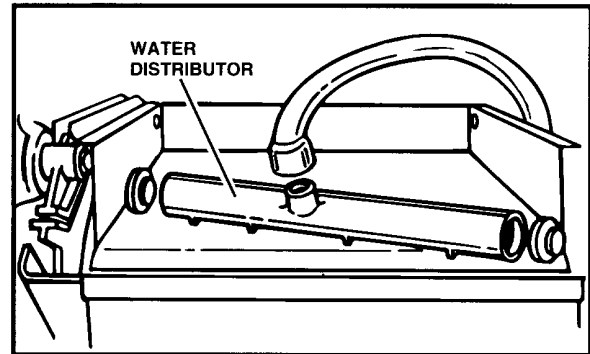

7. Wash the interior components (ice retainer baffle, cutter grid, water pan, inlet hose and water distributor) and the ice storage bin, door gasket and ice scoop with mild soap or detergent and warm water. The components should also be cleaned in a solution of 1/4 oz. of chlorine bleach mixed with 1 gallon of warm water.

Do NOT wash plastic parts in the dishwasher. They cannot withstand temperatures above 145°F. (63°C.)

8. Replace the interior components (water distributor, inlet hose, water pan, cutter grid, and ice retainer baffle).

9. Check the following:

- Hose from water valve is in the water pan.
- Rubber drain plug is in the water pan.
- Water distributor is seated and holes are facing down.
- Hose is reconnected to the pump and the water distributor.
- Hose from the water pan is inserted into the storage bin drain opening.

10. Reconnect the electrical harness, and slide cutter grid into place. Tighten the thumb screws.

CSWE1

Condenser

The air cooled condenser will also need to be cleaned periodically.

1. Turn the control knob to OFF.

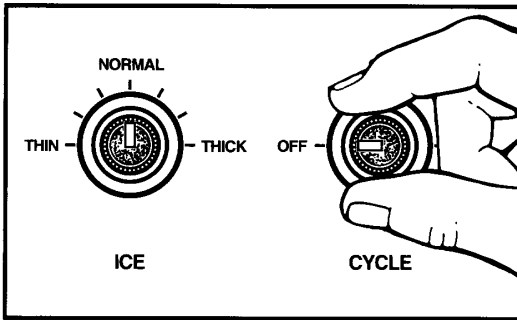

2. Remove the two screws in the lower grill area and the one screw from the center of the front panel support.

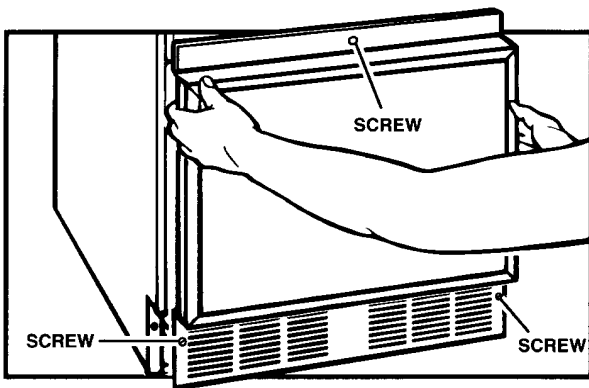

3. Pull forward and down to remove the lower access panel.

4. Remove dirt and lint from the condenser fins and the unit compartment with a brush attachment connected to a vacuum cleaner.

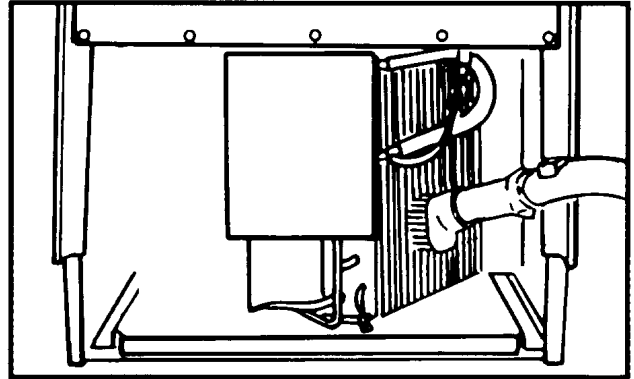

5. Return the lower access panel to its original position and attach with the original screws.

6. Turn the Control Knob to ON.

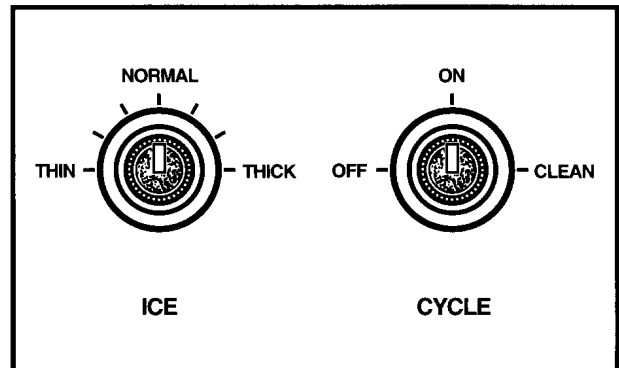

Service Diagnosis

Problem	Probable Cause	Possible Solution
Compressor will not run, no ice in bin	Located in cold area	Move to warmer area (above 55°F.)
	Power disconnected	Connect power
	Defective compressor start relay	Replace relay
	Service switch in OFF position	Move switch to ON
	Bin thermostat contacts open	Replace bin thermostat
	Defective compressor motor	Replace compressor
	Control knob in Clean position	Move to ON
Compressor runs, but no ice in bin	Water supply off	Restore water supply
	Inlet water valve does not work	Check valve, replace if needed
	Evaporator thermostat out of calibration	Re calibrate or replace
	Hot gas solenoid stuck "open"	Repair or replace
	Inoperative refrigeration system	Repair sealed system
	Excessive use of cubes	Advise customer
	Cutter grid circuit open	Check circuit
	Incorrect wiring	Check against wiring diagram
	Water inlet tube from valve not inserted into water pan	Insert tube into water pan
Compressor runs continuously, bin full of ice	Bin thermostat out of calibration	Re calibrate or replace
	Bin thermostat contacts stuck shut	Replace thermostat
	Incorrect wiring	Check against wiring diagram
Low ice yield	Located in cold area	Move to warmer area (above 55°F.)
	Water falling on cubes	Check water system components and see that they are in the proper place
	Bin thermostat out of calibration	Re calibrate or replace
	Evaporator thermostat set to produce cubes too thin or too thick	Adjust to 1/2" thick
	Hot gas solenoid stuck partially open	Replace solenoid valve
	Insufficient refrigeration	Check and repair sealed system
	Not enough water being circulated over the evaporator	Check for restriction in water lines. Check water pump and motor.

CSWE1

Service Diagnosis

Problem	Probable Cause	Possible Solution
Excessive water dripping on ice	Water pan overflowing	Check overflow tube for restrictions. Overflow hose not inserted in liner drain. Incorrect or worn flow washer in the inlet water valve.
	Water pan out of position	Install correctly
	Water inlet tube from water valve not inserted in water pan.	Locate tube properly.
	Ice jam on cutter grid causing water to flow into bin	Check cutter grid, check for mineral build up.
Mineral build up on evaporator	High mineral content in water	Clean the water system
Ice cubes too thin	Evaporator thermostat set for thin cube	Adjust thickness
	Non enough water being circulated over the evaporator	Check for restriction in water lines
		Check water pump and distributor tube
Evaporator thermostat out of calibration	Re calibrate or replace	
Ice cubes too thick	Evaporator thermostat set at or beyond maximum thickness	Adjust thickness
	Evaporator thermostat out of calibration	Re calibrate or replace
	Overcharge of refrigerant	Recover, evacuate, recharge with the nameplate charge of R-134a.
Condenser fan does not run	Fan blade stuck against something	Check fan blade
	Motor windings open or bearings seized.	Replace fan motor
	Open circuit in wiring	Check wiring
	Defective evaporator thermostat	Replace thermostat

Service Diagnosis

Problem	Probable Cause	Possible Solution
Water pump will not run	Pump binding in housing	Locate and remove cause of binding
	Open circuit in pump motor	Replace pump
	Open circuit to pump	Check wiring
	Defective evaporator thermostat	Replace thermostat
Water tank empty	On initial start up, water will not be in the tank until the evaporator thermostat stops the freeze cycle.	Normal
	Open circuit to water solenoid	Locate and repair wiring
	Complete water line restriction	Check for closed shut off valve
	Defective evaporator thermostat	Replace
	Water valve stuck closed	Replace valve
	Open coil on inlet water valve	Replace valve
	Water inlet tube from water valve not directing water to tank	Position outlet end of tube into water pan
	Water inlet screen or filter plugged	Clean screen, replace filter
White ice cubes	Water too hard (in excess of 400 ppm)	Water needs treatment
	Insufficient water supply in tank	Check for why not enough water Machine harvests ice too fast - less than one minute
Taste in ice	Foods stored in bin	Do not put foods in the bin
	Packaging material not all removed	Remove all packaging
Too much noise	Check tubing rattle from contact with tubes, cabinet, etc.	Reposition tubing

CSWE1

Operational Characteristics

Water Solenoid Valve

.25 GPM flow rate

Evaporator

Stainless steel

Refrigerant Charge

6.75 oz. of R-134a

Running amps

3.5

Cutter grid

8.5 volts

1.9 amps

Evaporator thermostat

Cut in: 38°F.

Cut out: 10 to -4°F.

Bin thermostat

Cut in: 41°F.

Cut out: 35°F.

System Pressures

Temperature	Suction Pressure at the end of the freeze cycle (PSIG)	Discharge pressure at the end of the freeze cycle (PSIG)	Cycle time in minutes
Air 70°F., water 60°F.	1 - 4	65 - 80	18 - 22
Air 90°F., water 60°F.	2 - 5	85 - 100	21 - 27
Air 100°F., water 60°F.	2 - 8	85 - 105	28 - 35
Air 70°F., water 80°F.	1 - 4	65 - 80	20 - 25
Air 90°F., water 80°F.	2 - 5	85 - 100	23 - 30
Air 100°F., water 80°F.	2 - 6	85 - 105	30 - 38

Index

A

Adjustment Page 5, Page 11, Page12

C

Cleaning Page 8 - Page10, Page 13

D

Door Panels Page 6

I

Installation Page 3 - Page4

L

Limitations Page 2

R

Refrigerant Page 2, Page 14